

KOMATSU®

WA470-5

NET HORSEPOWER
195 kW 261 HP @ 2.000 rpm
max. 202 kW 271 HP @ 1.700 rpm

OPERATING WEIGHT
23.500 kg

BUCKET CAPACITY
3,8 - 6,0 m³

WA
470

WHEEL LOADER



WA470-5

WALK-AROUND

The new WA470-5 wheel loader: The perfect combination of performance, comfort and economy. Never-before experienced comfort in the SpaceCab cabin, enormous tractive force and the lowest fuel consumption in it's class. And it's whisper-quiet in use, almost maintenance-free and incredibly productive with semiautomatic loading function (optional equipment). This is a wheel loader that has clearly earned its 5 stars!

Overwhelming Productivity

- High-torque low-emission engine with the latest common-rail injection
- Extremely low fuel consumption
- Choice of operating modes for engine and transmission
- Superior dumping height and reach
- Series production ECSS load stabiliser
- Semiautomatic loading function (option)
- Completely integrated payload meter (option)

For more detail, see page 4

Excellent Driving Convenience

- SpaceCab™ cabin
- Optimum all-around view
- Interior noise level is only 71 dB(A)*
- Air conditioning as standard
- 2-way adjustable steering column
- Air-cushioned high comfort seat
- Operation with PPC short levers or EPC fingertip control (option)

For more detail, see page 10



Diverse and Flexible

- Comprehensive range of attachments for a wide variety of uses

For more detail, see page 12

The 5 Star Loader

Ecological

- Meets TIER II emission regulations
- Exterior noise level 105 dB(A)*

*measured value

NET HORSEPOWER
195 kW 261 HP

OPERATING WEIGHT
23.500 kg

BUCKET CAPACITY
3,8 - 6,0 m³

Long Service Life and Reliable

- Reliable original Komatsu components
- Robust torsionally resistant frame
- Maintenance-free fully hydraulic, wet disc service and parking brakes
- Heavy-duty axles
- Sealed DT wiring harness connector

For more detail, see page 7



Easy Maintenance

- EMMS monitoring system
- Cab controlled reversible fan
- Swing-out oil and air to air charge cooler for easy access and cleaning
- Gull-wing doors for easy ground level access
- Extended engine oil change interval
- Centralised lubrication system as standard

For more detail, see page 8

OVERWHELMING PRODUCTIVITY

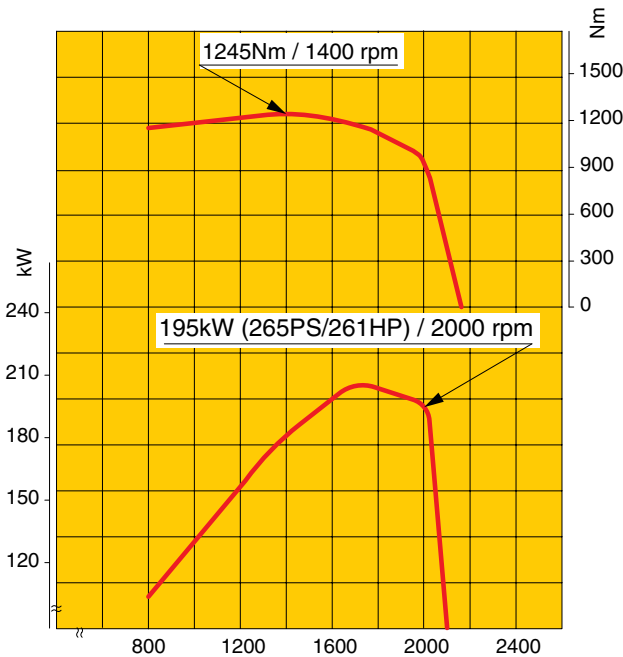

Extremely high-torque engine

The Komatsu low emission engine SAA6D125E-3 produces 195 kW (261 HP) at 2.000 rpm. When the engine is loaded below the rated speed, the power increases continually because of a higher injection quantity. This means that you can achieve greater traction and lifting power in conjunction with this great increase in torque, producing very fast working cycles. The engine reaches its peak performance of 202 kW (271 HP) in its typical speed range of 1.700 rpm.

When digging / scooping

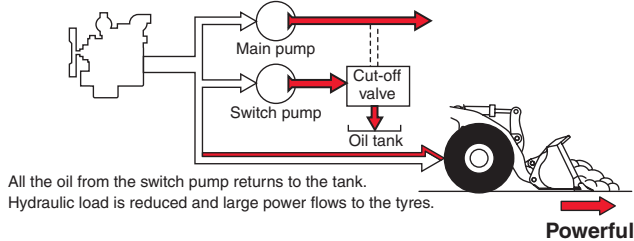

When raising the boom

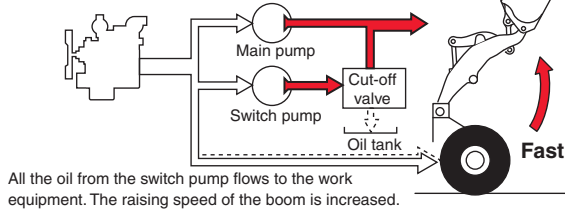

New 2-stage hydraulic system

The working hydraulic system adapts itself excellently to your specific needs: The main and switch pump together supply great capacity for high-speed loading cycles. The main pump alone supplies a reduced oil quantity for force and the maximum tear-out strength. And there's something new: when you press the kick-down switch, the alternate pump is switched off. This means that the maximum tractive force is available while simultaneously lifting the bucket. This is important, for example, when loading feed hoppers on a steep ramp.

Maximum dumping height and reach

The long lifting frame allows an enormous dumping height of 3.130 mm and a reach of 1.325 mm that is just as impressive (with 4,1 m³ universal bucket, measured to the cutting edge).

With this working range, loading high-sided semi-trailers with a payload of 28 tonnes becomes child's play.





Excellent stability and manoeuvrability

With a tread width of 2.230 mm and a long wheelbase of 3.450 mm, the WA470-5 offers you overwhelming stability in all working situations.

The turning circle over tyres of only 6.205 mm means you can work efficiently even in the tightest spaces.

Mode selector switch for the engine

The operator can simply change between two modes depending upon the job. In the **Normal** mode, fuel consumption is clearly reduced by utilising a reduced-power characteristic map for the engine. This is of benefit with all general loading work. If the operator switches to **Power**, he immediately has the maximum power, for instance for hard digging or driving up steep inclines.



Mode selector switch for the transmission

The transmission of the WA470-5 can also be adapted brilliantly to every need with the selector switch. The transmission selector switch allows the operator to select between manual transmission shifting and three automatic modes (high, medium and low). You can also find the perfect setting from saving the maximum fuel and the highest power by moving the gear-changing time depending upon speed.



NEW OPTIONS FOR EVEN GREATER PRODUCTIVITY



Faster Load & Carry with torque converter lockup

The operator may also utilise direct drive in third and fourth gear for optimum efficiency in Load & Carry. Clearly the speed increases, especially when driving uphill where the wheel loader travels significantly faster because of the increase in tractive force. At the same time, the converter loss is eliminated, thus clearly reducing fuel consumption.



Semiautomatic dig

Something new in the world is Komatsu's patented function of semiautomatic bucket filling. A pre-programmed bucket filling process is carried out with the aid of the electrical pilot control. This means that it is no longer necessary to manually move the bucket lever when driving into material. This also means that operators with little experience still have productive loading cycles. And for the professionals, it's noticeably easier to operate with greater convenience.



Payload meter

The new payload weigh scale allows perfect control of loading processes and loading power. The large and easily read display in the middle of the main monitor shows the operator a pictorial representation of each bucket load and the material quantity already loaded. Various modes allow you to alternately display the weight already loaded or how much the operator still has to load for a pre-set amount. The system also allows you to store and print out the daily output and loading output of five different materials.



LONGEVITY AND RELIABILITY

Quality you can rely on!

The engine, transmission, torque converter, front and rear axles are original Komatsu components. All of these component parts are subject to the highest quality requirements and strict quality assurance right down to the smallest screw. They are fully co-ordinated with one another, thus offering maximum efficiency and reliability.

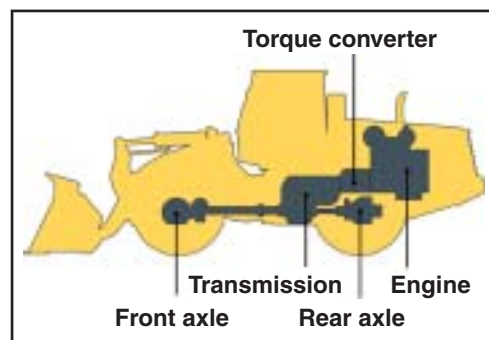

Torsionally resistant frame

The frame design with hinge points far apart guarantees the high stability for the overall construction and reduces bearing stress in the torsional ranges. Steering angles of 40° give the WA470-5 a high degree of manoeuvrability.



Robust HD-axes

The heavy-duty axles allow above-average service life even under the hardest working conditions. The WA470-5 can also have the optional equipment of multiple-disc limited slip differentials to further increase tractive force.



Reliable construction equipment engines

Komatsu's reliable engine, with thick walled crank case, was developed with low noise and robustness in mind.



Reliability right down to the details

All of the hydraulic connections are reliably protected against oil loss by Komatsu's O-ring seals. Komatsu's hydraulic cylinders are equipped with special guide rings to protect and support the cylinder rods. The electrical system is also designed for long-lasting operation (without breakdowns) with its dust- and water-proof DT plug-and-socket connections in the wiring harnesses.

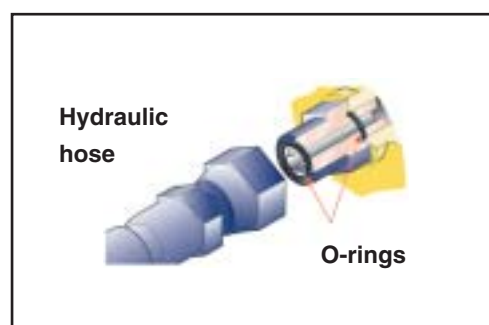

SIMPLE AND FAST MAINTENANCE



Simple and convenient access to service

The service doors are designed as gull-wing doors. They allow you convenient and safe access to the daily service points from the ground.



Reversible hydraulic radiator fan and swingout coolers

The radiator fan can be switched to reverse operation from the cabin for work in dusty environments. Furthermore, oil cooler and air to air charge cooler can be swung out for easy access and fast cleaning.



EMMS (Equipment Management Monitoring System)

This completely new type of monitoring system is clearly structured and easy to read because it is directly in the operators field of view. If there is a malfunction, it immediately displays the details in the chosen national language and in plain text in the display field. This system not only has an error memory and a self-diagnosis function, but also a service interval display. This significantly simplifies service work and the operator is notified on time of the regular oil and filter changes. The operator and customer-service engineer are constantly informed about the optimum machine state so that problems don't even occur in the first place.

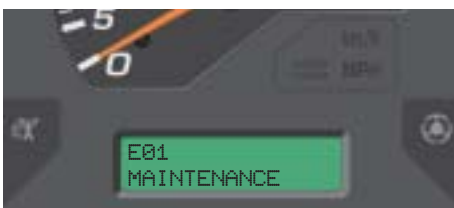

Maintenance-free braking system

The fully hydraulic dual-circuit service brake with multi-disc brakes running in an oil bath offers you the highest degree of safety and a long service life. Something new is the fact that the braking system can be operated with even greater precision. Since it functions completely hydraulically, you no longer have the drawbacks of a compressed air braking system. The benefits of the new system are that weathering has no effect on it, it is available for work immediately after starting the engine and it's maintenance free. The multi-disc internal parking brake is also maintenance free.

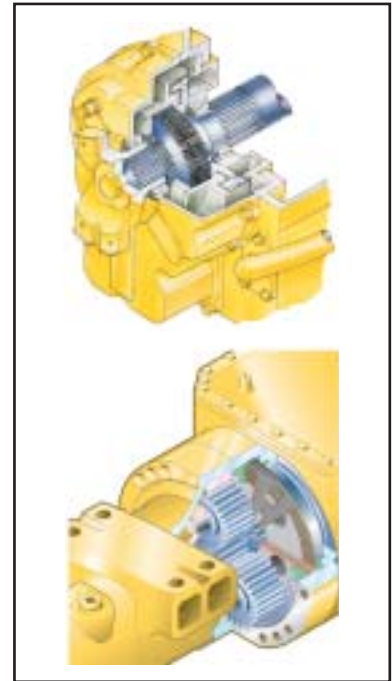

Centralised lubrication system as standard

The centralised lubrication system reduces the daily service work to the absolute minimum. Its robust piping with protective equipment in all areas ensures constant lubrication amounts, operating reliability and electronic monitoring with a malfunction signal in the cabin. This increases the machine's service readiness and service life while lowering repair and service costs.



Customer service and spare parts supply

When you buy a Komatsu construction machine, you buy a lot more than just the product alone. Our service support accompanies you throughout the entire life of your wheel loader. Programs for preventative maintenance are just as much a part of what we offer as the complete range of dealer service and repair programmes. And, if there is a malfunction, Komatsu's close-knit network of dealers and excellent parts service ensures you minimum downtime.



THE SPACECAB



Perfect driving convenience and the best all-round visibility

The cabin is the largest in its class and offers you unparalleled driving convenience comparable to that of a passenger car. The large frameless windscreen, ensures an optimum view of the bucket and tyres, and the slanted rear end also gives an excellent view towards the rear. The cabin is mounted on viscose shock absorbers guaranteeing an interior noise level of only 71 dB(A), one of the lowest in this class. That together with air conditioning as standard ensures the operator's well-being just as much as the air-cushioned multi-adjustable premium drivers seat with head rest, seat heater and lumbar support. The easy-to-work hydraulic operating controls on the multi-adjustable hydraulic console makes it possible to operate the wheel loader conveniently and ergonomically. The operator's well-being is ensured over long and productive hours.

SIMPLE & CONVENIENT OPERATION

Adjustable steering column with built-in monitor unit

The steering column with continuous tilt and height adjustment incorporates the monitoring system allowing the entire unit to be brought into the most favourable position for each individual operator. The two-spoke steering wheel makes it possible to read all of the displays and instruments without any problems.



Automatic transmission with variable transmission cut-off

The electronically controlled automatic transmission with mode selection allows you to conveniently adjust to each job. The operator can continuously adjust the transmission cut-off activated through the left brake pedal: for instance, reacting to high cut-off pressure when excavating or low pressure for smooth braking when approaching lorries.



New and easy-to-use joystick steering (option)

A new Joystick steering system is available as optional equipment, and ensures that steering can be wrist operated easily and conveniently in loading operations. This system allows you to change the direction of travel and gear shifting with push buttons on the joystick. And you may pre-select the steering speed in 2 stages, depending upon whether fast V-loading or precise Load & Carry is required.



Smooth ergonomic hydraulic control

The new pilot control levers are designed as finger tip control levers for precise and fatigue-free control of the loading process. The position of the levers and the location of the entire console can be adjusted for all operators preferred height and reach. EPC equipment is also available as optional equipment for controlling the working hydraulic system. Apart from the electronic pilot control of the finger levers, EPC offers a modulating function for slowing and stopping bucket movements when lowering, that is vibration-free. Furthermore, the upper and lower boom cut out position can be pre-set with a switch that ensures major ease of operation for the operator when work is constantly changing such as in loading lorries. As a third feature, EPC equipment has a semiautomatic excavating function for simple filling buckets (also refer to page 6).

A multifunctional lever design is also available as optional equipment.



BUCKETS AND ATTACHMENTS



Universal bucket

This type of bucket is impressive because of its excellent penetration and loosening properties and its good material holding properties.

This universal bucket can be equipped with flush mount adapters and interchangeable teeth.



Earthmoving bucket

The earthmoving bucket with a one-piece bucket bottom is suited both for earthworks and loading cohesive material. The slanted sides give powerful penetration. It is equipped either with flush mount adapters and interchangeable teeth or also with a rear removable edge.



Rock bucket

V-shaped buckets offer excellent penetration properties for medium heavy-duty rock jobs.

Robust hardox design wear plates ensure a long service life. We have a selection of optional equipment with the high wear-resistant K VX™ cutting tools for extremely abrasive jobs.



Maximum dumping height with High-Lift

The dumping height and reach can be increased for special jobs with the optional high-lift lifting frame. You may increase dumping height by approximately 51 cm and the reach is increased by approximately 14 cm.



Hydraulic quick coupler

The WA470-5 can change attachments in a matter of seconds with the HD designed hydraulic quick coupler, available as optional equipment.



A comprehensive range of attachments

The timber grab: With its sturdy structure and its great hydraulic power and a special tilting cylinder, the WA470-5 is also perfectly suited to work in the timber industry. The robust design of the lifting frame and axles ensure maximum durability.

SPECIFICATIONS



ENGINE

Type Komatsu SAA6D125E-3
 water-cooled, 4-stroke, turbocharger
 Rated capacity..... 195 kW/261 HP (SAE J1349)
 at engine speed2.000 rpm
 Maximum capacity..... 202 kW/271 HP (SAE J1349)
 at engine speed1.700 rpm
 Torque/engine speed max. 1.245 Nm/1.400 rpm
 No. of cylinders 6
 Bore x stroke 125 x 150 mm
 Displacement..... 11,04 l
 Injection system..... Common-rail,
 controlled by characteristic diagram
 Lubricating system Gear pump, pressure feed lubrication filter
 Filter..... Main-flow filter
 Electrical system 24 V
 Battery 143 Ah
 Alternator..... 50 A
 Air-filter type Dry-air filter with automatic dust emission
 and preliminary purification including a dust display



TRANSMISSION

Torque converter..... One-stage, one-phase, 3-element
 Transmission..... Automatic powershift transmission
 Speeds in km/h
 Gear 1. 2. 3. 4.
 with 26.5 R25 tyres / with torque converter lockup:
 forwards 6,3 12,1 22,8 39,7
 backwards 6,7 12,8 24,7 40,9
 with 26.5 R25 tyres / without torque converter lockup:
 forwards 6,3 12,1 21,7 34,9
 backwards 6,7 12,8 23,0 36,0



CHASSIS AND TYRES

System..... 4-wheel drive
 Front axle.....HD axle, semi-floating,
 (LSD-differential optional)
 Rear axleHD axle, semi-floating,
 30° swing angle (LSD-differential optional)
 Countershaft..... Spiral bevel gear
 Differential Straight bevel gear pair
 Final drive Planetary gear in an oil bath
 Tyres 26.5 R25 (standard)



SERVICE REFILL CAPACITIES

Cooling system..... 50 l
 Fuel tank..... 390 l
 Motor oil..... 38 l
 Hydraulic system 186 l
 Axle (both front and rear axle)..... 52 l
 Torque converter and transmission 60 l



BRAKES

Operating brakes Completely hydraulic dual-circuit system,
 running in oil bath
 multi-disc brakes
 on all wheels,
 service-free
 Parking brake..... Operated electrohydraulically,
 running in oil bath
 multi-disc brake,
 service-free
 Emergency brake Uses the parking brake



HYDRAULIC SYSTEM

Hydraulic pump..... Gear pump
 Working pressure 210 bar
 Circulating capacity of the hydraulic pump 294 + 116 l/min
 No. of hydraulic/bucket cylinders 2/1
 Type Double-action
 Bore diameter x stroke
 Hydraulic cylinder..... 180 x 764 mm
 Bucket cylinder..... 200 x 575 mm
 Hydraulic control lever Pre-controlled, 2-levers
 Hydraulic cycle with rated load bucket filling
 Stroke time..... 6,0 s
 Lowering time (empty) 3,7 s
 Dumping time..... 1,4 s



STEERING SYSTEM

System..... Articulated frame steering
 Type Completely hydraulic power steering
 Steering angle to either side..... 40°
 Steering pump Gear pump
 Working pressure 210 bar
 Pumping capacity 142 l/min
 No. of steering cylinders 2
 Type Double-action
 Bore diameter x stroke 100 x 441 mm
 Smallest turn (outer edge of the tyre 26.5 R25) 6.205 mm



CABIN

Two-door cabin in conformity with ISO 3471 with ROPS (roll over protective structure) in conformity with SAE J1040c and FOPS (falling object protective structure) in conformity with ISO 3449. The air-conditioned pressurised cabin is mounted upon hydrobearings and is noise dampened.

The noise level in the cabin is in accordance with the dynamic measurement in conformity with ISO 6396:
 with blower: 72 dB(A)
 without blower: 71 dB(A)

DIMENSIONS AND PERFORMANCE FIGURES

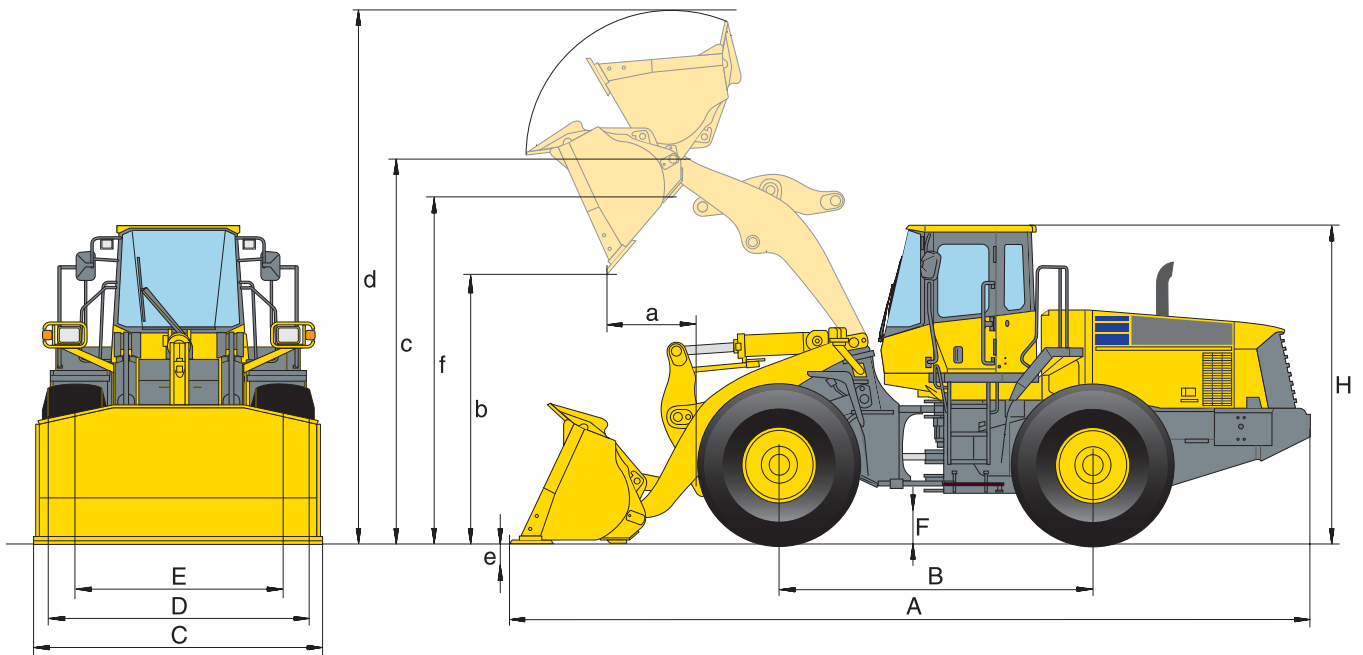
Measurements and working specifications

Bucket type		Universal				Earthmoving			
		w/o teeth	with BOC	w/o teeth	with BOC	w/o teeth	with BOC	w/o teeth	with BOC
Bucket capacity (heaped, ISO 7546)	m³	4,1	4,3	4,5	4,7	4,2	4,4	4,4	4,5
Sales Code	3921-	C01	C03	C11	C13	C41	C45	C46	C50
Material density	t/m ³	1,85	1,80	1,70	1,65	1,80	1,75	1,75	1,70
Bucket weight without teeth	kg	1.690	1.915	1.900	2.135	2.115	2.340	2.195	2.430
Static tipping load, straight	kg	18.905	18.680	18.695	18.460	18.480	18.255	18.400	18.165
Static tipping load, 40° articulated	kg	16.495	16.270	16.285	16.050	16.070	15.845	15.990	15.755
Break-out force hydraulic	kN	184	175	184	175	182	173	183	174
Lifting capability hydr. at ground level	kN	238	233	238	233	237	232	237	232
Operating weight (without add. counterw.)	kg	22.780	23.005	22.990	23.225	23.205	23.430	23.285	23.520
Turning radius at corner of tyres	mm	6.205	6.205	6.205	6.205	6.205	6.205	6.205	6.205
Turning radius at bucket edge	mm	6.980	7.035	6.895	6.950	6.900	6.955	6.975	7.030
a Reach at 45°	mm	1.325	1.380	1.325	1.380	1.335	1.390	1.330	1.385
b Dump height at 45°	mm	3.130	3.055	3.130	3.055	3.115	3.040	3.120	3.045
c Hinge pin height	mm	4.340	4.340	4.340	4.340	4.340	4.340	4.340	4.340
d Height top edge of bucket	mm	5.990	5.990	5.990	5.990	5.990	5.990	5.990	5.990
e Digging depth	mm	65	95	65	95	65	95	65	95
f Max. loading height at 45°	mm	4.025	4.025	4.025	4.025	4.025	4.025	4.025	4.025
A Overall length, bucket grounded	mm	8.890	8.965	8.865	8.940	8.885	8.960	8.875	8.950
B Wheelbase	mm	3.450	3.450	3.450	3.450	3.450	3.450	3.450	3.450
C Bucket width	mm	2.990	3.000	3.160	3.170	2.990	3.000	3.160	3.170
D Width over tyres	mm	2.903	2.903	2.903	2.903	2.903	2.903	2.903	2.903
E Track width	mm	2.230	2.230	2.230	2.230	2.230	2.230	2.230	2.230
F Ground clearance	mm	525	525	525	525	525	525	525	525
H Overall height	mm	3.460	3.460	3.460	3.460	3.460	3.460	3.460	3.460

All measurements with tyres 26.5 R25 L3. If fitted with tyres sized 23.5 R25: dump heights -65 mm, dump reaches +65 mm.

Details given are for buckets without teeth; if equipped with teeth: dump height -180 mm, dump reach +180 mm, overall length +255 mm.

Change in data caused by:

		Add. counter-weight	Equipment with teeth
Weight	kg	+ 400	+ 150
Stat. tipping load, straight	kg	+ 1.070	- 150
Stat. tipping load, 40° angle	kg	+ 895	- 150
Overall length (A)	mm	+ 190	-

with High-lift frame:

		Add. counter-weight*	Equipment with teeth
Weight	kg	+ 1.040	+ 100
Stat. tipping load, straight	kg	+ 1.740	- 100
Stat. tipping load, 40° angle	kg	+ 1.495	- 110
Overall length (A)	mm	+ 590	-

* Standard for High-Lift

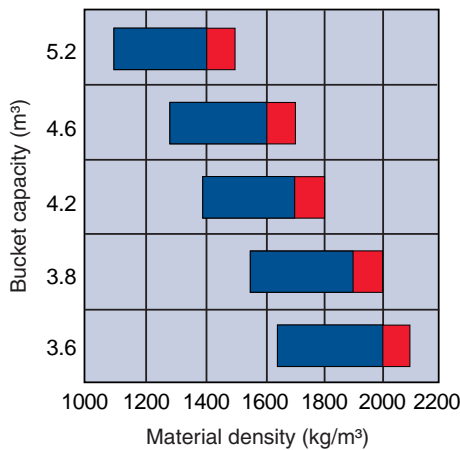

Stockpile				Heavy Duty			
w/o teeth	with BOC	w/o teeth	with BOC	w/o teeth	with BOC	w/o teeth	with BOC
4,6	4,8	4,8	4,9	4,1	4,3	4,1	4,3
C43	C70	C48	C71	C27	C29	C35	C37
1,65	1,60	1,60	1,55	1,85	1,80	1,85	1,80
2.360	2.585	2.450	2.685	2.215	2.450	2.245	2.470
18.235	18.010	18.145	17.910	18.380	18.145	18.350	18.125
15.825	15.600	15.735	15.500	15.970	15.735	15.940	15.715
173	165	177	169	195	190	185	176
232	227	234	229	244	241	238	234
23.450	23.675	23.540	23.775	23.305	23.540	23.335	23.560
6.205	6.205	6.205	6.205	6.205	6.205	6.205	6.205
6.925	6.980	6.990	7.045	6.935	6.990	6.900	6.955
1.380	1.435	1.355	1.410	1.275	1.330	1.195	1.250
3.060	2.985	3.085	3.010	3.090	3.015	3.175	3.100
4.340	4.340	4.340	4.340	4.340	4.340	4.340	4.340
5.990	5.990	5.990	5.990	5.955	5.955	5.920	5.920
65	95	65	95	125	155	125	155
4.025	4.025	4.025	4.025	4.025	4.025	4.025	4.025
8.960	9.035	8.925	9.000	8.740	8.815	8.855	8.930
3.450	3.450	3.450	3.450	3.450	3.450	3.450	3.450
2.990	3.000	3.160	3.170	3.160	3.170	2.990	3.000
2.903	2.903	2.903	2.903	2.903	2.903	2.903	2.903
2.230	2.230	2.230	2.230	2.230	2.230	2.230	2.230
525	525	525	525	525	525	525	525
3.460	3.460	3.460	3.460	3.460	3.460	3.460	3.460

Typical material density – loose (in kg/m³)	
Basalt	1.960
Bauxite, Kaolin	1.420
Earth, dry, ex store	1.510
Earth, wet, excavated	1.600
Gypsum, broken	1.810
Gypsum, crushed	1.600
Granite, broken	1.660
Limestone, broken	1.540
Limestone, crushed	1.540
Gravel, unscreened	1.930
Gravel, dry	1.510
Gravel, dry, 6-50 mm	1.690
Gravel, wet, 6-50 mm	2.020
Sand, dry, loose	1.420
Sand, damp	1.690
Sand, wet	1.840
Sand and clay, loose	1.600
Sand and gravel, dry	1.720
Sandstone	1.510
Slate	1.250
Slag, broken	1.750
Stone, crushed	1.600
Clay, natural	1.660
Clay, dry	1.480
Clay, wet	1.660
Clay and gravel, dry	1.420
Clay and gravel, wet	1.540

WHEEL LOADER

STANDARD EQUIPMENT

- | | | | |
|--|--|---|--|
| <ul style="list-style-type: none"> • Universal bucket 4,1 m³ (SAE, heaped) • Automatic return-to-dig • Automatic boom kick-out • Counterweight • Hydrostat-driven radiator fan with reversing function • Swing-out oil and air to air charge cooler • 2-spool main control valve • Central automatic lubrication • Electronically controlled, load stabilizer (ECSS) 2nd generation • Fully hydraulic brake system • Corrosion resistor • Power train guard • Tyres 26.5 R25 L-3 | <ul style="list-style-type: none"> • Heavy-duty axles • Electronically controlled ECMV automatic transmission with mode selector and variable transmission cut-off • Alternator 50 A • Starter motor 11 kW/24 V • Batteries 143 Ah/2×12 V • Spacious double door driver's cab to DIN/ISO • ROPS/FOPS frame to SAE • All-round tinted glazing • Front laminated glass • Electronically controlled air conditioning • Heated rear window • Rear window wiper • Air-suspended, heated seat | <ul style="list-style-type: none"> • Sun visor • Seat belt (EU standard) • PPC fingertip control, two levers • EMMS (Equipment Management Monitoring System) with self-diagnostic function and maintenance display • Vertically- and horizontally-adjustable steering column with integrated monitor • Stereo-cassette radio • 2 halogen main headlights • 2 spotlights at front and rear • Reversing light • Horn • Handrails on left/right | <ul style="list-style-type: none"> • Emergency steering system • Vandalism protection • Tool-set <p>The WA470-5 is equipped in accordance with the safety regulations of the machinery guidelines 89/392 EWG ff and EN474, and corresponds in its exhaust gas emission values with the regulations of the EC 2000/14, VIII and EC 97/68 Stage II regulations.</p> |
|--|--|---|--|

OPTIONAL EQUIPMENT

- | | | | |
|---|--|---|--|
| <ul style="list-style-type: none"> • High-lift equipment including high-lift counterweight 1.040 kg • 3-spool main control valve • Add. counterweight 400 kg • Limited-slip differential (LSD) front and rear • Torque converter lock-up • Tyres 23.5 R25 • Tyre guard chains • Universal bucket 4,3 m³ • Universal bucket 4,5 m³ • Universal bucket 4,7 m³ • Earthmoving bucket 4,2 m³ • Earthmoving bucket 4,4 m³ • Earthmoving bucket 4,5 m³ • Stock pile bucket 4,6 m³ • Stock pile bucket 4,8 m³ • Stock pile bucket 4,9 m³ | <ul style="list-style-type: none"> • Heavy-duty bucket 4,1 m³ • Heavy-duty bucket 4,3 m³ • Trapezoidal rock bucket 3,8 m³ • Light materials bucket 6,0 m³ • Various tooth systems, BOC, segments, (Komatsu/KVX™) and other optional bucket accessories are available on request • Quick coupler • Log grapples • Special buckets • Batteries 180 Ah/2×12 V • Joystick steering with integrated F/R transmission function, 2-stage • PPC control, 1-lever (Multi-function lever) | <ul style="list-style-type: none"> • Electronic 2-lever control (EPC) including: <ul style="list-style-type: none"> - Bucket stop modulation - Boom stop pre-setting - Semi-automatic dig function • Payload meter • Back-up alarm • Beacon light • Additional lights front and rear • Front screen protective grid • Cab air safety system • Exhaust gas particles filter • Turbo II pre-filter • Electronic anti-theft lock • 20 km/h version • Full rear fenders • Battery main switch • Fire extinguisher | <ul style="list-style-type: none"> • Biodegradable oil for hydraulic system • Special paintwork • Wastehandler specification • Steelhandler specification • Tunnel specification • Anti-Corrosion specification • General operating certification, in accordance with German Road Traffic Regulations. <p>Further equipment on request.</p> |
|---|--|---|--|



Komatsu Europe International NV
 Mechelsesteenweg 586
 B-1800 VILVOORDE (BELGIUM)
 Tel. +32-2-255 24 11
 Fax +32-2-252 19 81
 www.komatsueurope.com

VESS074806 05/2004

Materials and specifications are subject to change without notice.

KOMATSU is a trademark of Komatsu Ltd. Japan.